

Pneumatic Nailer Type 850 DCC

The coil nailer type 850 DCC is a compact and well balanced tool for heaviest applications. The tool that powerful that ring shank nails will countersink even into hardwood. The 850 DCC drives wire welded nails with diameters from 2.5 to 3.1 mm and in the lengths from 60 to 80 mm.

The comfortable rubber grip and the adjustable exhaust make the tool operator friendly.



Popular applications:

Pallets, siding, cases, sheathing, sub flooring, house construction.

Length: 337 mm
Width: 133 mm
Height: 362.5 mm

Technical Data

Type description:	850 DCC Standard
Article code:	12000452
Magazine type :	Coil magazine / top loader
Safety:	Contact actuation
Fastener type:	BDC
Magazine capacity:	1 coil
Nails per coil:	Ø 2.5 = 300, Ø 2.8 = 250, Ø 3.1 = 200
Operating pressure:	5 – 8 bar
Max. operating pressure:	8 bar
Air consumption/operation:	2.2 litre / 6 bar
Inner hose diameter:	Ø 9 mm LW recommended
Emission sound pressure level at the workstation:	L pA, 1s, d= 90 dB
Single-shot emission sound pressure level:	L WA, 1 s,d= 97 dB
Weight:	3.5 kg
The vibration as per document no. CEN/TC 255 WG 1 N 47.3 is 4.3 m/s ²	
Extras supplied with the nailer:	Operating instructions, spare parts list, service instructions For safety reasons we recommend the BeA single release if working pressure allows this.

Subject to technical modifications.

Pneumatic Nailer Type 850 DCC

BDC - nails
(wire welded nails)

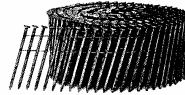

Joh. Friedrich Behrens AG
P.O.Box 14 80
D-22904 Ahrensburg
Phone: +49 (0) 4102 78-0
Fax: +49 (0) 4102 78-250
www.bea-group.com
e-mail: info@bea-group.com

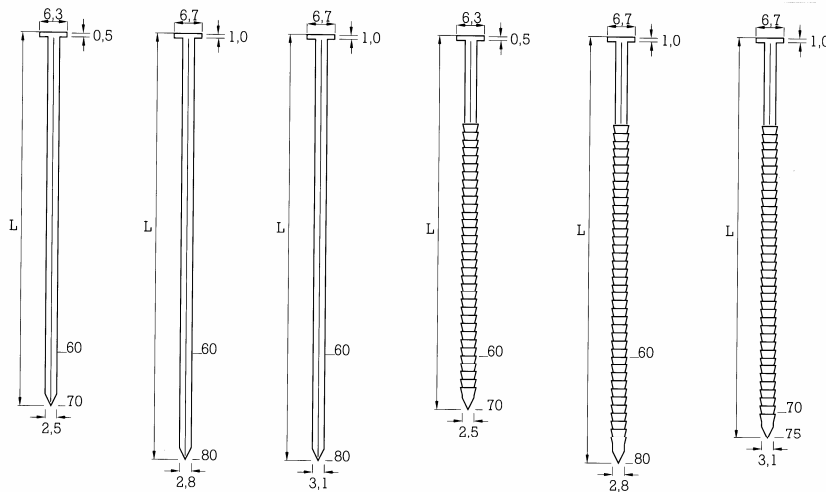

Description	L = Length mm
BDC 2,5 x 60 BK	60
BDC 2,5 x 65 BK	65
BDC 2,5 x 70 BK	70
<hr/>	
BDC 2,8 x 60 BK	60
BDC 2,8 x 65 BK	65
BDC 2,8 x 75 BK	75
BDC 2,8 x 80 BK	80
<hr/>	
BDC 3,1 x 70 BK	70
BDC 3,1 x 75 BK	75
BDC 3,1 x 80 BK	80
<hr/>	
BDC 2,5 x 60 BK Ring	60
BDC 2,5 x 65 BK Ring	65
BDC 2,5 x 70 BK Ring	70
<hr/>	
BDC 2,8 x 60 BK Ring	60
BDC 2,8 x 65 BK Ring	65
BDC 2,8 x 70 BK Ring	70

Nails are also available in NK (galvanized steel), NR (stainless steel) and with ring shank on request.

Explanations:

NK = galvanized steel	BK = bright steel	LM = aluminium	HZ = resin coated
NKS = galvanized steel, extra hard	BKS = bright steel, extra hard	NR = stainless steel, material. 1.4401	DP = divergent point
NKH = galvanized steel, hard	MS = brass	RF = rust resistant, material 1.4301	SA = step cut

